



COUNTER CURRENT UNIT

Instruction Manual

Introduction:

Congratulations on your purchase of a new Certikin counter current swimming unit. This unit has been developed and built by qualified personnel especially for swimming pool use.

It is your responsibility to ensure that all recommendations, as far as transport, installation, connection, maintenance and repair of the unit, as detailed in this manual are strictly adhered to.

Both air and water volume output can be controlled from the directional inlet on the face plate assembly.

The top of the range auto prime pump enables the unit to achieve maximum output with minimum noise.

Take the time to read the installation and commissioning manual carefully in order to ensure that you get the most from your counter current swimming unit.

General instructions

Nozzle assembly:

Should be positioned at more than 300mm from the minimum water level (fig 1)

All connections should be vertical

The inlet end of the air entry tube should be situated above the water level of the pool

The PVC pipes and connections used to connect the pump to the nozzle should be assembled according to the indications in the Plumbing Assembly Chapter.

All the technical instructions provided should be followed carefully. The safety and the efficiency of the counter-flow current unit are only guaranteed if the commissioning and installation instructions are respected.

Kit contents

Part Code	Description	C - Concrete	PF - Liner	L - Prefabricated
	Counter Current Jet (Front Part)	1	1	1
	Counter Current Jet (Housing)	1	1	1
AQP301 / AQP303	Pump	1	1	1
GP200BV	Ball Valve	2	2	2
GP20090	90 degree Elbow	1	1	1
GP20045	45 degree Elbow	2	2	2
	Crystal Hose	2	2	2
	Adhesive Seal	0	2	2
	Air Tube	1	1	1
CBCC-M / CBCC-T	Electric Control Box	1	1	1
	Screw M6 x 35	4	4	4
	Screw M6 x 24	0	16	16
	Screw 4.8 x 25	0	0	8

Assembly instructions

Housing assembly

4

For concrete pools (C)(fig 2)

Locate the housing as shown in fig 2. ensuring that the connections are vertically aligned.

For panelled pools (L and DL)(fig 3)

Locate the fastening flange, ensuring that the recommended distance above the water level and the vertical alignment of the connections are respected.

Trace the position of the external crown of the fastening flange

Cut the panel following the line traced around the external crown of the flange

Place the housing on the panel and trace the position of the 8 holes

Fix the housing onto the panel using the 4.8 x 25 screws.

For Polyester Pools or liner pools (PF)(fig 4)

Locate the fastening flange, ensuring that the recommended distance above the water level and the vertical alignment of the connections are respected.

Using the fastening flange trace the position of the screws and the internal crown

Make the 14 fixing holes on the panel/liner and cut out following the interior flange diameter

Flange assembly 2 (Panelled and liner pools PF & L)

Clean all surfaces of the flange and housing onto which the seal will be attached

Stick the seals onto the surfaces

If the pool is a liner pool

position the liner and fill the pool to just below the housing

Fix the flange onto the housing using 16 M6 x 24 screws.

Front part assembly 1

Fix the air tube (Ø5mm, length 3000mm) on the push button keeping it on the outside of the casing (fig 5).

Check that air flows through the tube when the push button is operated

Unscrew the gland seal completely in order to pass the air tube through it

Ensure that the air tube is pulled as far through the clear hose as possible

Fix the air-hose connection (ready assembled onto the housing) onto the front part.

Screw the front part onto the housing taking care not to crush the air connection or the air tube

Attention: The air inlet tube MUST be ABOVE the pool water level and the inlet must be protected from foreign bodies.

Connecting counter current jet to the pump

IMPORTANT NOTE: If the pump is installed more than 1 metre from the counter current jet the Ø63mm tubes, valves and elbows MUST be replaced by Ø90 mm.

Before connecting the counter current unit to the pump the housing and the pump must have been installed as above.

Prepare all the PVC tubes

After assembly ensure that there are no leaks

see (fig 7)

Glue the 90/63 and 75/63 reducers(1) onto the rear housing connectors at the rear of the housing (2)

Attach the reducers to the ball valves (3) using the PVC pipes (shown in grey on the diagram)

Attach the ball valves to the pump (4) using the 90° and 45° elbows supplied (ensure the valves are fitted in the right way) fig 8.

Plumbing assembly

To join any parts in PVC please follow the following guidelines:

Carefully sandpaper the surfaces to be glued

Clean the sanded surfaces with a special PVC degreaser

Glue the parts together with a special PVC pressured adhesive

Join the parts together - please note that drying time is often short!

Electro-pneumatic connection

Check that the power supply is correct for the equipment

The Electrical box and the push button should never be more than 10m apart.

Ensure that the electrical box CANNOT come into contact with water.

Follow the specific instructions supplied with the electrical box

Connect the air tube to the on/off switch

Operation

Once the counter current swimming unit is installed check the rotational direction of the pump motor. The air and flow rates can then be regulated, as shown in fig 9.

Winterising

In case of exceptionally cold weather or hard frosts it is necessary that the front part of the Counter swim unit be disassembled.

Unscrew the screws which attach the front part of the housing

Disconnect the air tube from the push-button

Disconnect the front part of the air inlet tube

Put 2 plugs inside the housing inlets

Completely empty the pump (see electrical pump for swimming pool/ installation and maintenance manual).

Annexes

Fig 1 Counter current positioning

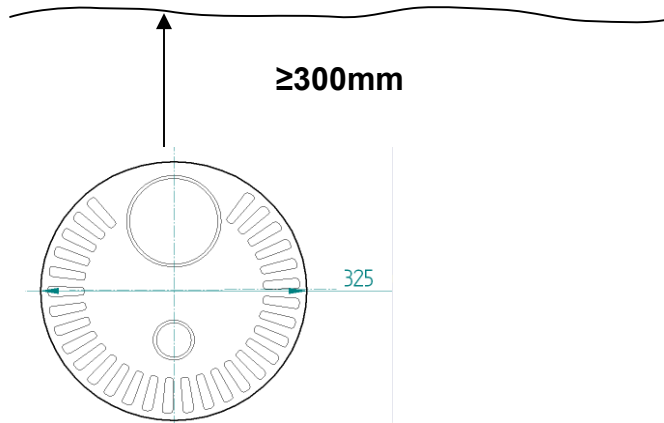

Fig 2 Concrete swimming pool

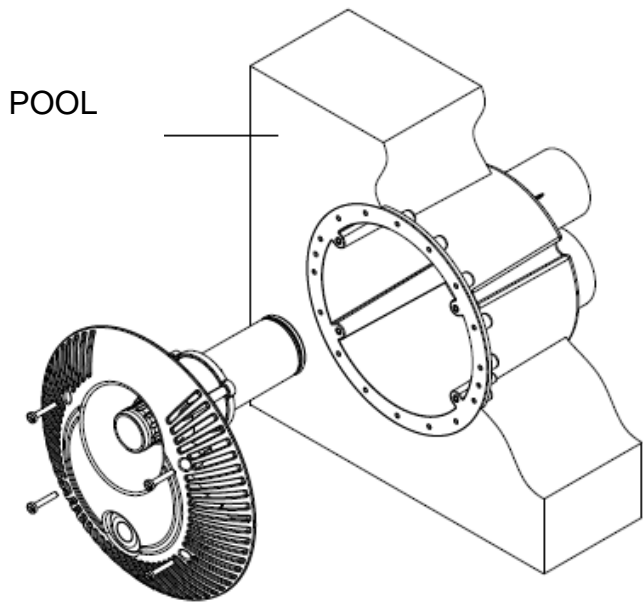

Fig 3 Panelled + liner

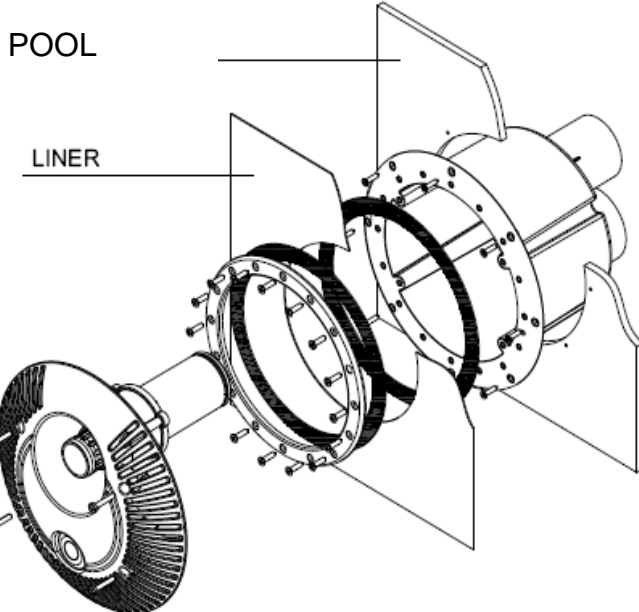

Fig 4 Prefabricated or liner pools

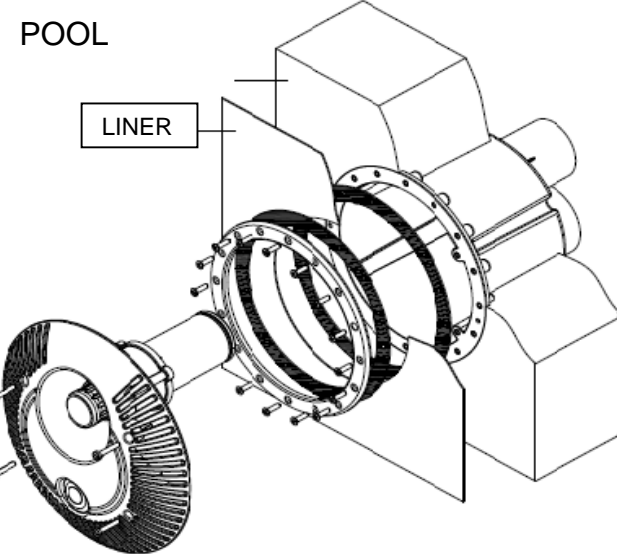
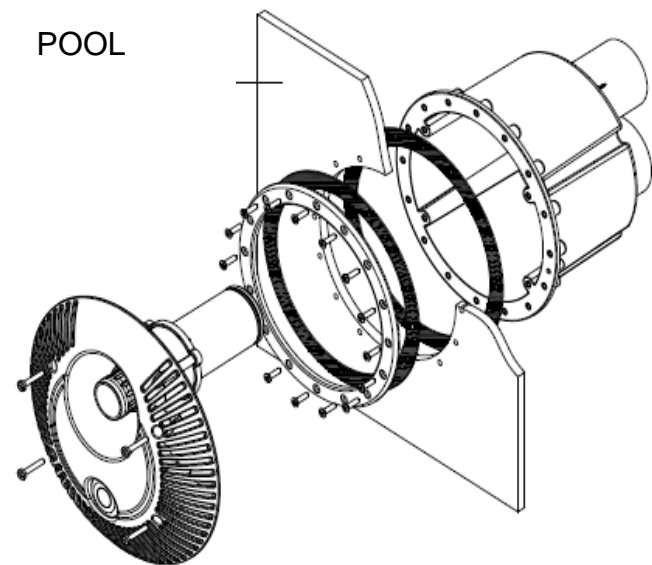

Figure 1

Fig 5 Pneumatic Pushbutton

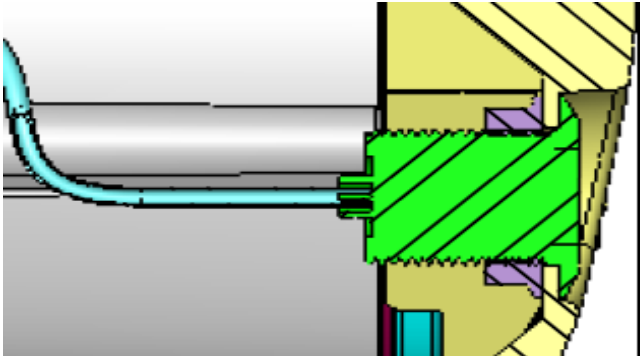

Fig 6 Air aspiration

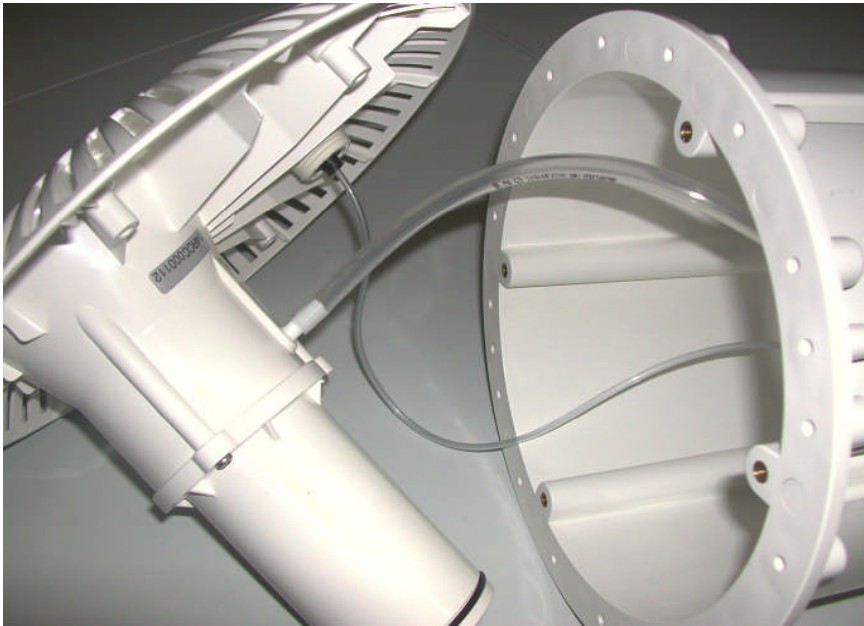

Fig 7 Assembly

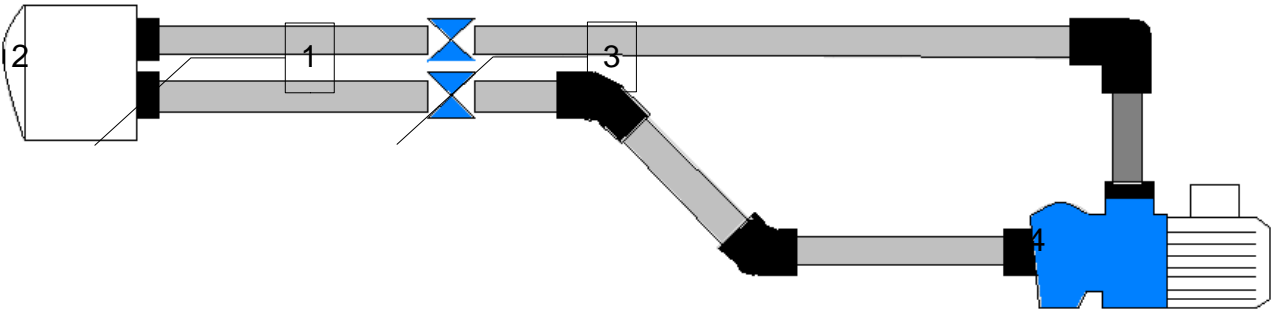

Fig 8 Ball valve

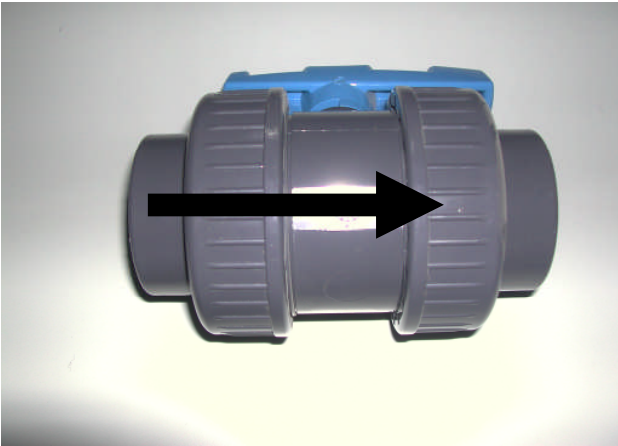
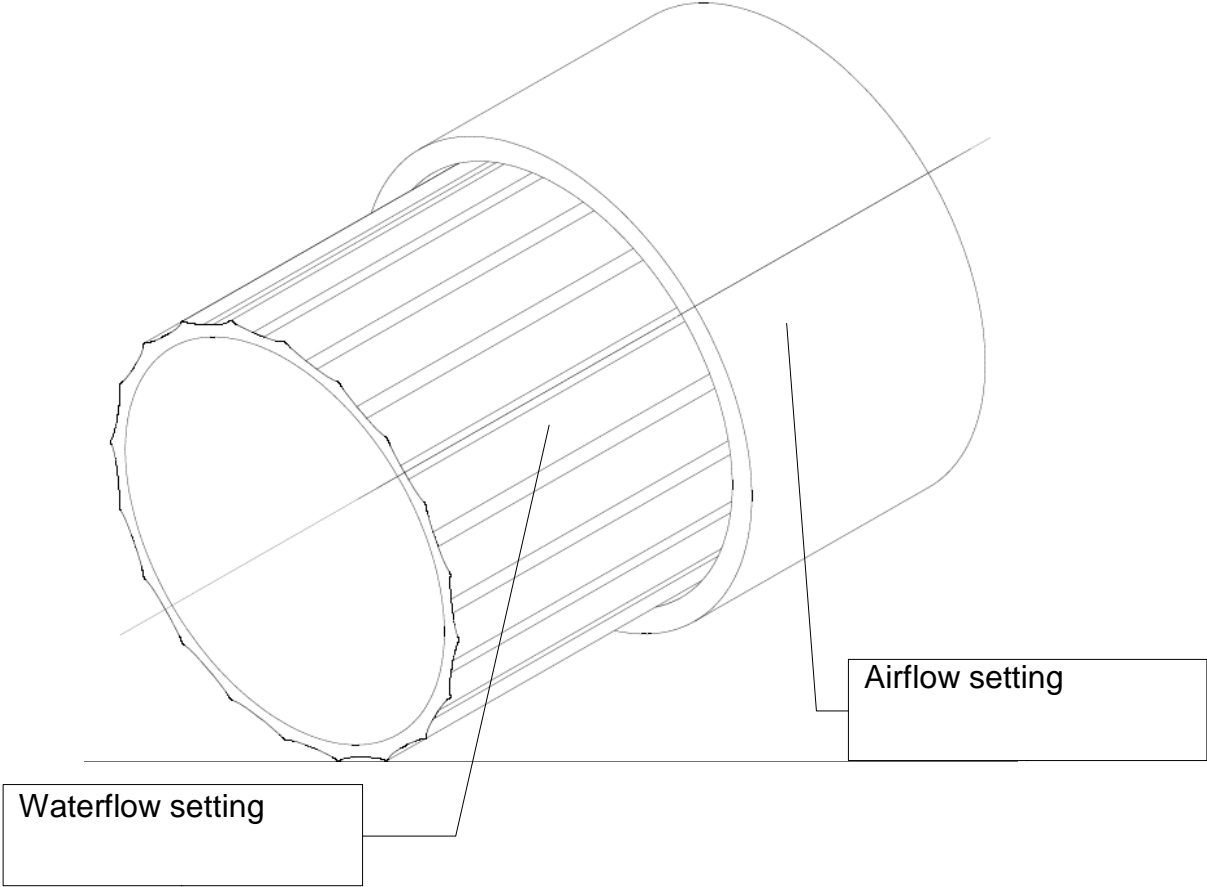
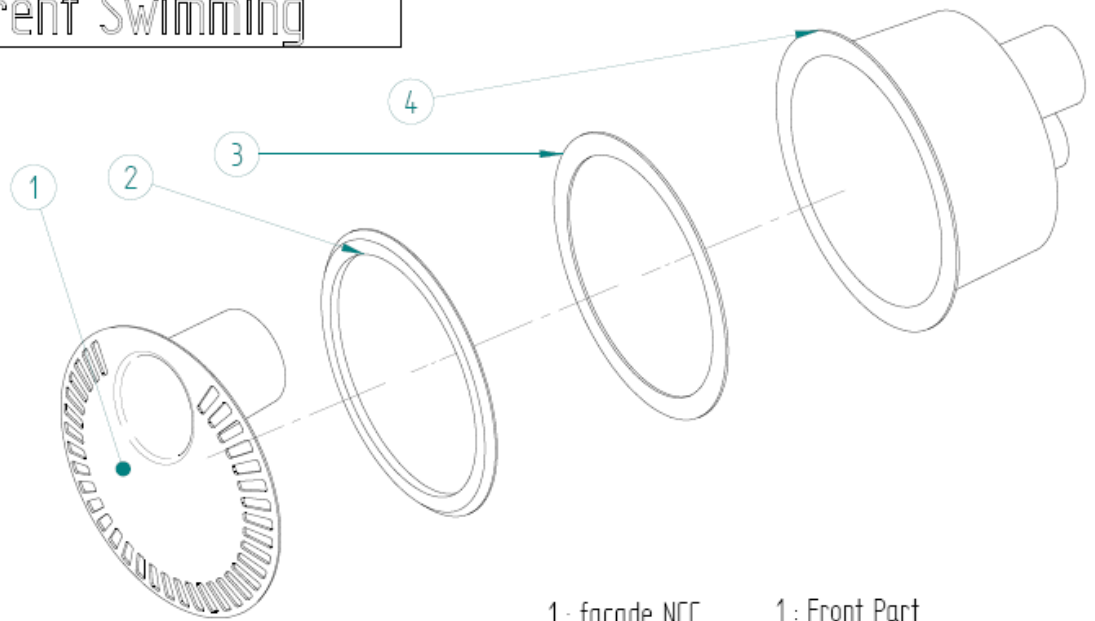

Fig 9



Nage à contre courant Counter Current Swimming



- | | |
|----------------|----------------|
| 1 : facade NCC | 1 : Front Part |
| 2 : bride NCC | 2 : flange |
| 3 : Joint NCC | 3 : seal |
| 4 : Niche NCC | 4 : housing |